

Part number:



QTM3

FLOW RESTRICTOR VALVE

SERIES 10

MODULAR VERSION ISO 4401-03

p max 350 bar
Q max (see table of performances)

MOUNTING INTERFACE

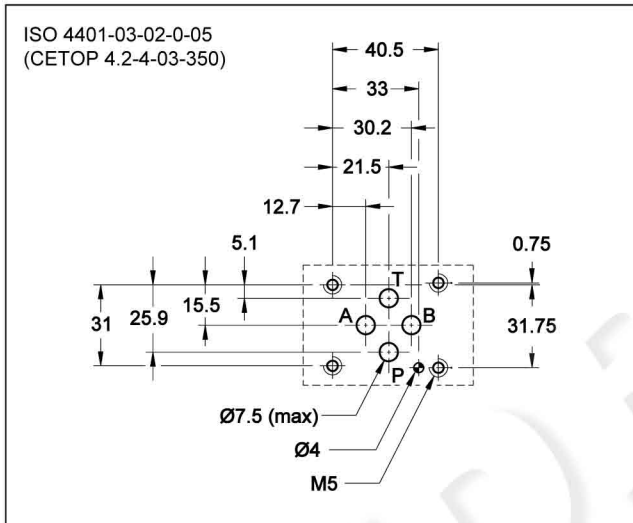

OPERATING PRINCIPLE

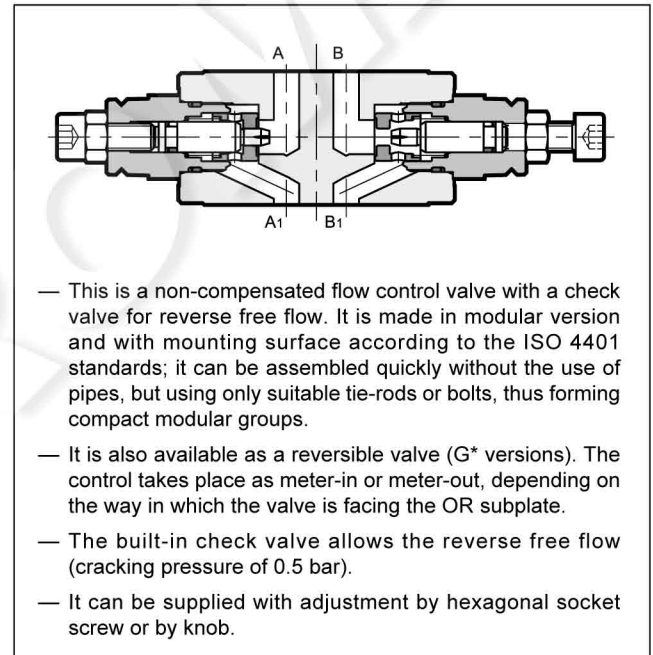

PERFORMANCES (measured with mineral oil of viscosity 36 cSt at 50°C)

Maximum operating pressure	bar	350
Check valve cracking pressure		0.5
Maximum flow rate in the controlled lines		50
Maximum flow rate in the free lines	l/min	75
Min. controlled flowrate with Δp 10 bar		≤ 0.060
Ambient temperature range	°C	-20 / +60
Fluid temperature range	°C	-20 / +80
Fluid viscosity range	cSt	10 ÷ 400
Fluid contamination degree	According to ISO 4406:1999 class 20/18/15	
Recommended viscosity	cSt	25
Mass	kg	1.3

HYDRAULIC SYMBOLS

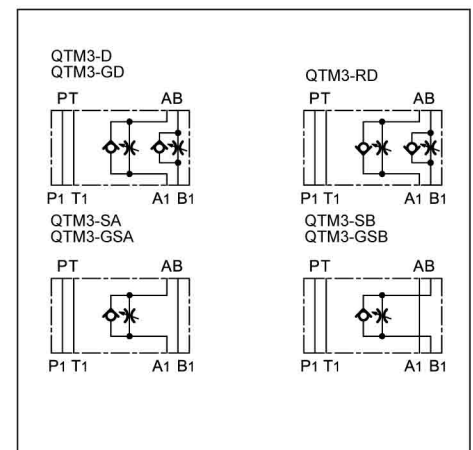

1 - IDENTIFICATION CODE

Q	T	M	3	-		/	10	/		
----------	----------	----------	----------	----------	--	----------	-----------	----------	--	--

Flow restrictor valve with check valve for reverse free flow

Modular version

ISO 4401-03 size

Configurations:
D: meter-out control in lines A and B (**standard**)
RD: meter-in control in lines A and B
SA: meter-out control in line A
SB: meter-out control in line B

Configurations G* - reversible valve (**NOTE 1**)
GD: control in lines A and B
GSA: control in line A
GSB: control in line B

Option:
/W7 = Zinc-nickel surface treatment (see **NOTE 2**)
 Omit if not required

Adjustment type:
S = with hexagonal socket screw (**standard**)
CK3 = with push, adjust, lock knob (see point 6)

Seals:
N = NBR seals for mineral oil (**standard**)
V = FPM seals for special fluids

Series No.
 (the overall and mounting dimensions remain unchanged from 10 to 19)

NOTE 1: The valve body does not provide the OR seats. The mounting interface is achieved by interposition of an OR subplate (included in the delivery). The control of flow (meter-in or meter-out) is depending on the way of assembly the valve on the subplate.

NOTE 2: The standard valve is supplied with surface treatment of phosphating black.
 The zinc-nickel finishing on the valve body makes the valve suitable to ensure a salt spray resistance up to **240** hours. (test operated according to UNI EN ISO 9227 standards and test evaluation operated according to UNI EN ISO 10289 standards).

2 - CHARACTERISTIC CURVES

(values obtained with viscosity of 36 cSt at 50°C)

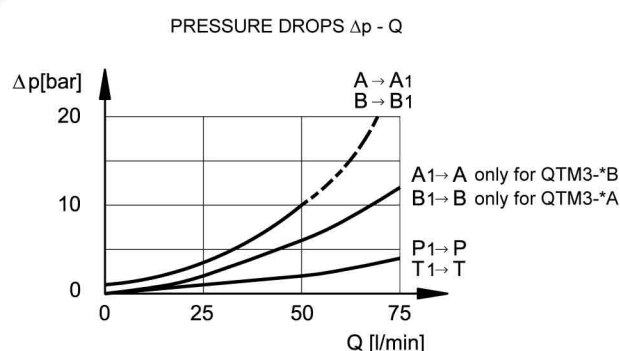
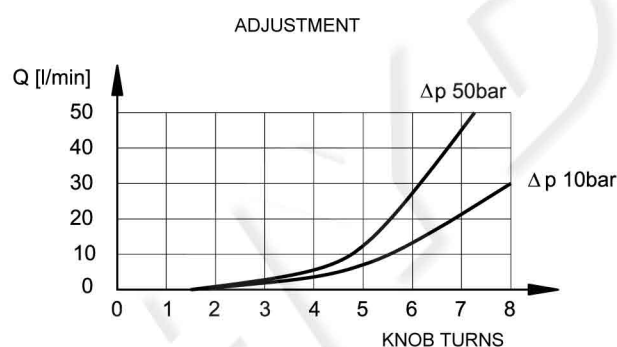

3 - HYDRAULIC FLUIDS

Use mineral oil-based hydraulic fluids HL or HM type, according to ISO 6743-4. For these fluids, use NBR seals. For fluids HFDR type (phosphate esters) use FPM seals (code V). For the use of other kinds of fluid such as HFA, HFB, HFC, please consult our technical department.

Using fluids at temperatures higher than 80 °C causes a faster degradation of the fluid and of the seals characteristics. The fluid must be preserved in its physical and chemical characteristics.

4 - QTM3 -D, -RD AND -S* - OVERALL AND MOUNTING DIMENSIONS

dimensions in mm

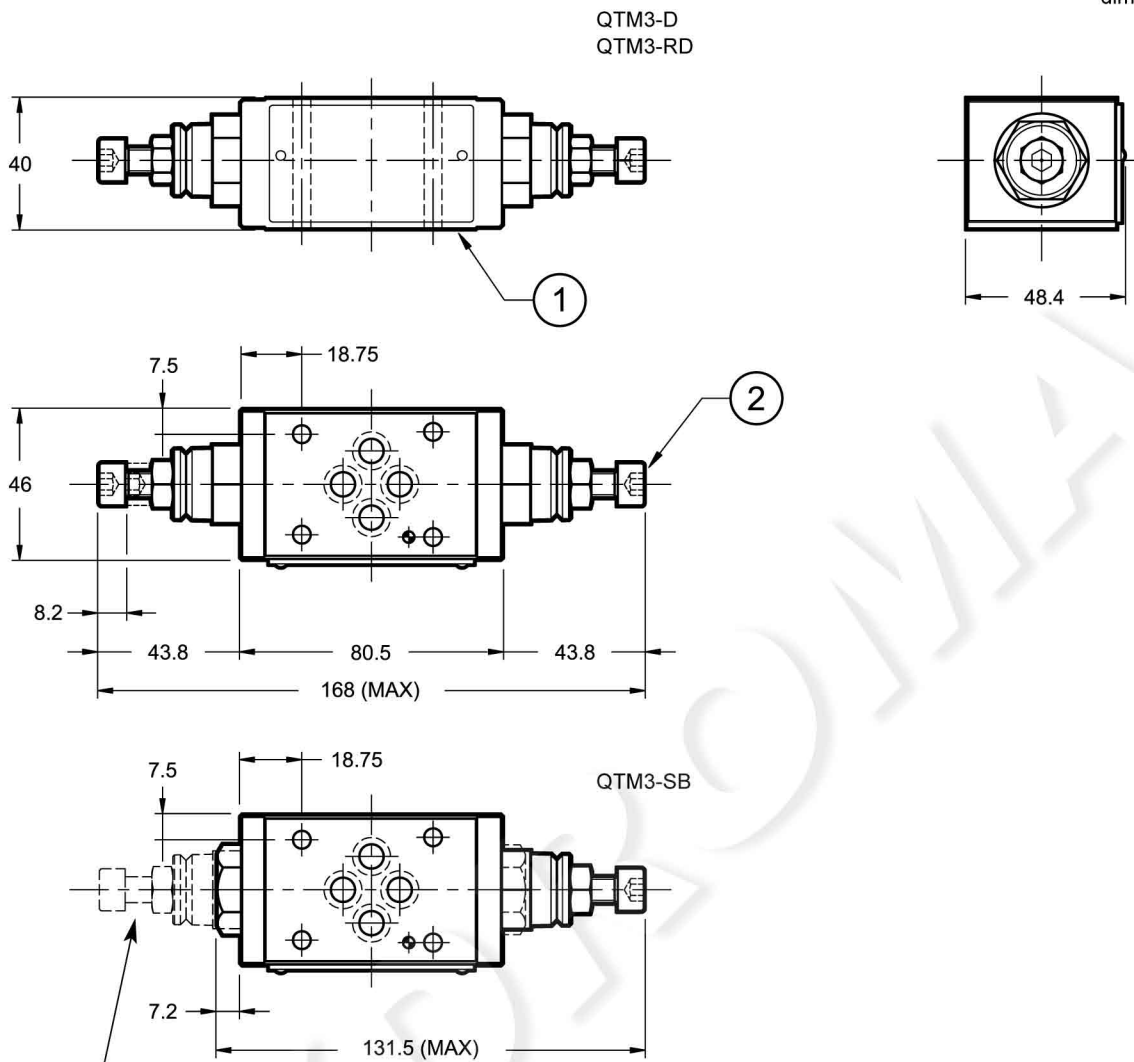

adjustment screw on QTM3-SA

1	Mounting surface with sealing rings: N. 4 OR type 2037 (9.25x1.78) 90 Shore
2	Socket hex adjustment screw: Hex key 6 Rotate anticlockwise to increase flow

5 - QTM3-G* - OVERALL AND MOUNTING DIMENSIONS

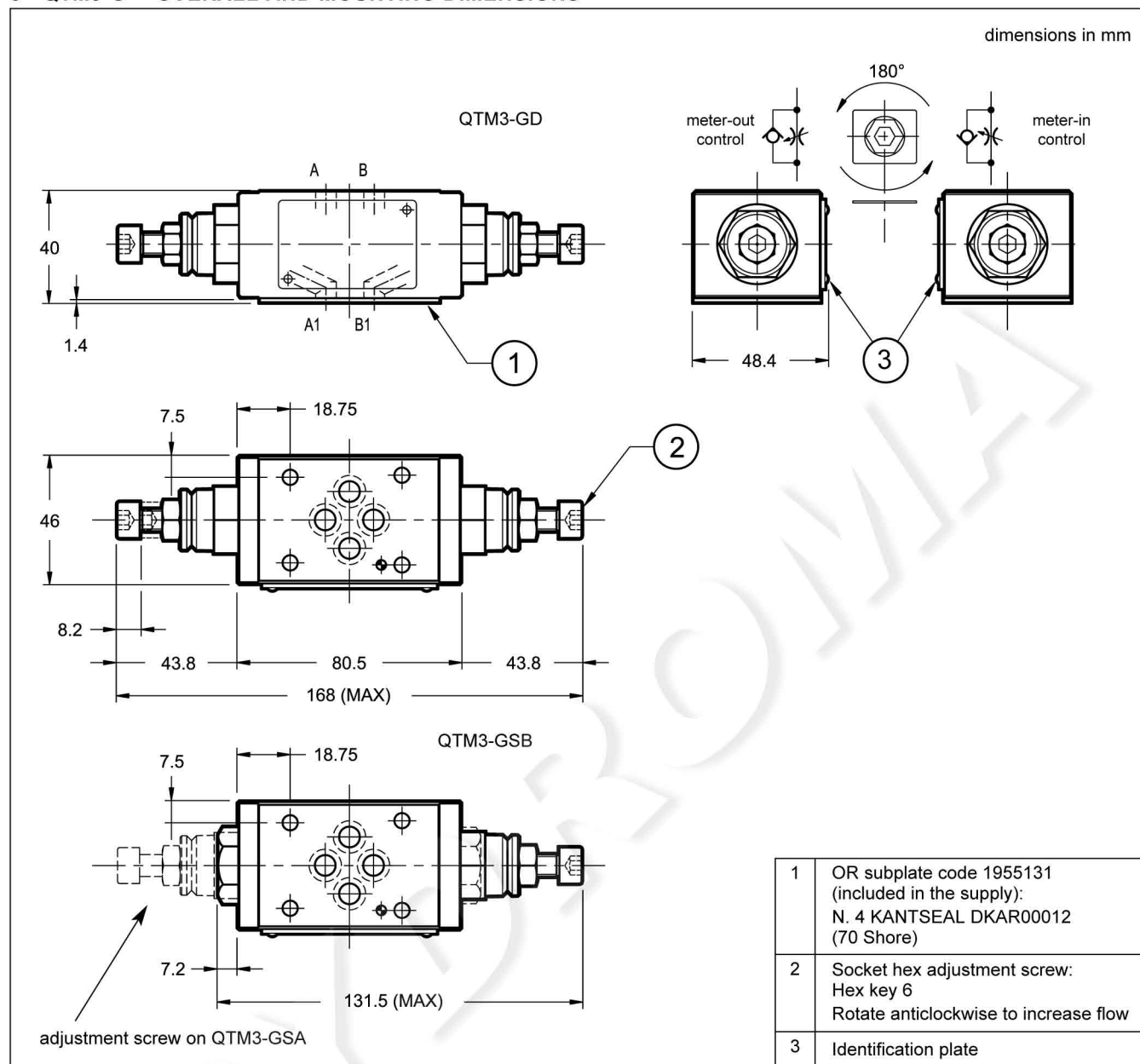

6 - ADJUSTMENT KNOB

Valves can be supplied with adjustment knob, which is engaged by pushing and twisting at the same time. When released, the knob disengages to secure the adjustment from involuntary tampering.

Add **CK3** in the identification code to order this version (see point 1).

