

Part number:

HYDROMA
HYDRAULICKÉ SYSTÉMY

HIDROMA
SYSTEMS
UKŁADY HYDRAULICZNE

HYDROMA
ГИДРАВЛИЧЕСКИЕ СИСТЕМЫ

DGMS - 3

MULTI-STATION (IN-LINE) MANIFOLDS

| KE 7045 | 09/13 |

D_n 06 | p_n 35 MPa

Multistation manifolds DGMS-3 are basic elements for in-line mounting of hydraulic circuits in vertical stacking assemblies

Dn 06, NG 06 | 1-8 sections |
Steel DIN 5355 3263 | Installation dimensions
according to: CETOP RP 121-H (CETOP 3),
ISO 4401-03, DIN 24340

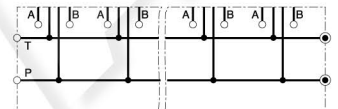
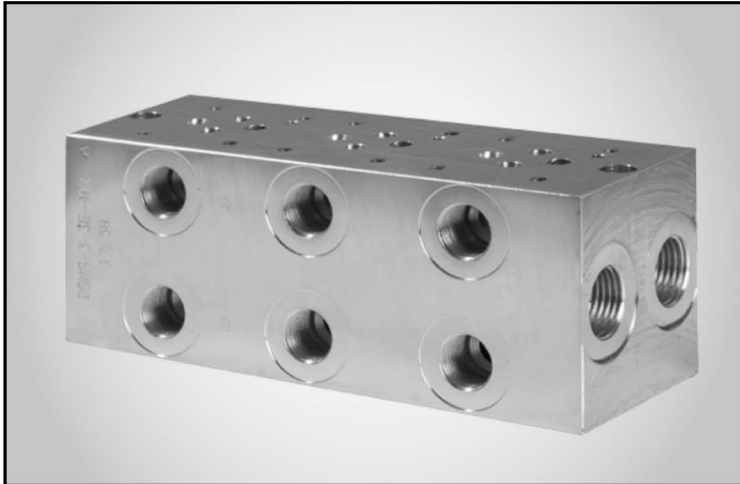

FUNCTIONAL DESCRIPTION

Multi-station manifolds DGMS-3 provides an economical way of building vertical stacked hydraulic circuit using sandwich plate valves in combination with directional valve of size D_n 06. All hydraulic circuits have a common pressure and tank ports (P, T) that are situated on each end of the manifold. Each control circuit has a separate actuator ports (A, B) situated on the frontal area of the manifold.

INSTALLATION, SERVICE AND MAINTENANCE

Multi-station manifolds DGMS-3 can be installed in any working position. Port cavities are designed for pipe or hydraulic hose connection. For cavity dimensions of P, T, A, B ports see the chapter Cavity dimensions of this datasheet. Machined pad must be provided if any section is not used.

DELIVERY

Fittings, machined pads with sealing and mounting screws are not included in the package. These must be ordered separately.

ORDERING CODE

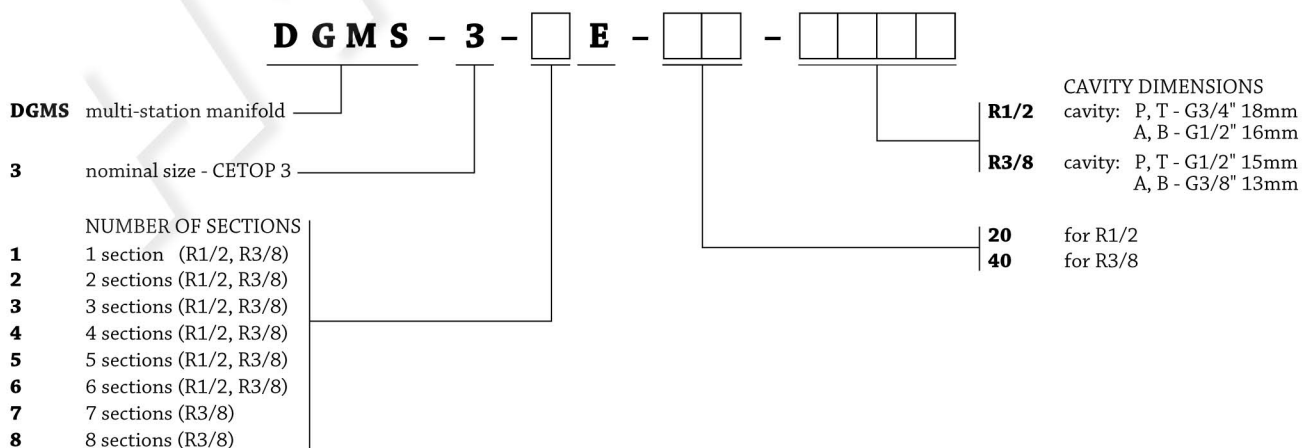

TECHNICAL DATA

	Symbol	Unit	Value
Nominal pressure	p_n	MPa	35
Fluid temperature range	t_{po}	°C	-20 up to +80
Ambient temperature range	t_k	°C	-20 up to +70
Hydraulic medium		Hydraulic oils of power class (HL,HLP) according to DIN 51524	
Weight	m	kg	see Manifold dimensions
Surface treatment		Nickel plated	
Material		Steel DIN 5355 3263	

MANIFOLD DIMENSIONS

DGMS-3-xE-40-R3/8

x - number of sections (1 ÷ 8)

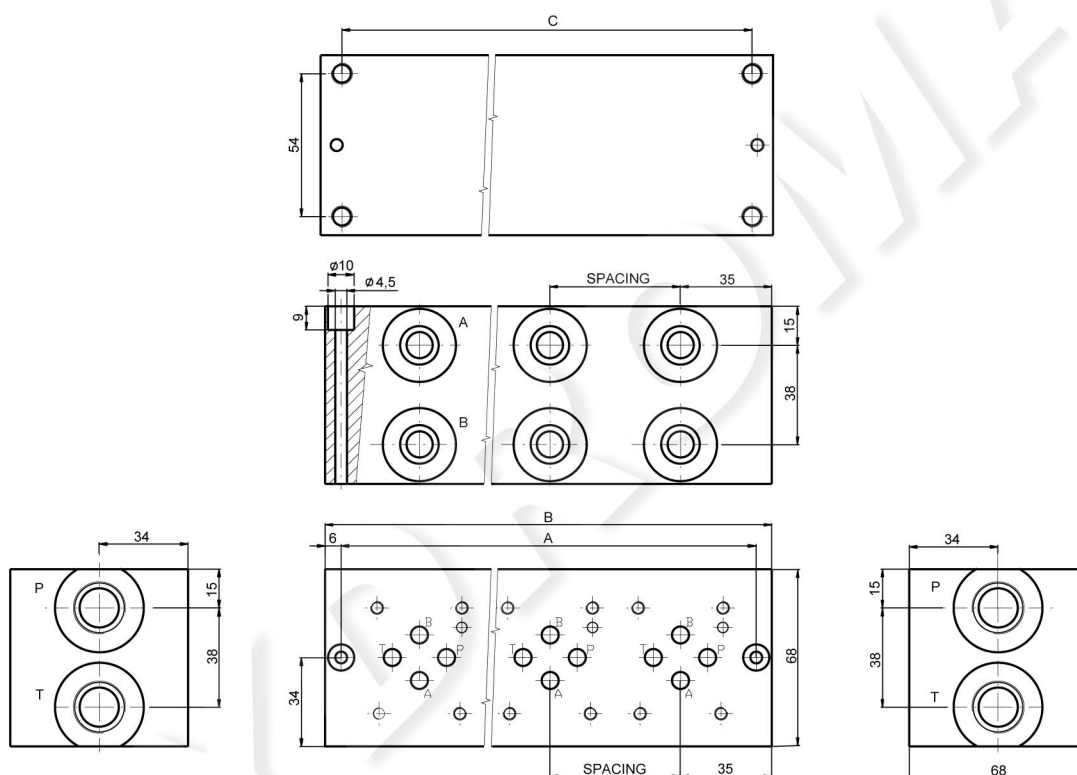

Type	x	A	B	C	Spacing	Weight [kg]
DGMS-3-1E-40-R3/8	1	58	71	55	-	2,2
DGMS-3-2E-40-R3/8	2	108	121	105	50	3,8
DGMS-3-3E-40-R3/8	3	158	171	155	50	5
DGMS-3-4E-40-R3/8	4	208	221	205	50	7
DGMS-3-5E-40-R3/8	5	258	271	255	50	8,2
DGMS-3-6E-40-R3/8	6	308	321	305	50	10
DGMS-3-7E-40-R3/8	7	358	371	355	50	11,8
DGMS-3-8E-40-R3/8	8	408	421	405	50	13,6

DGMS-3-xE-20-R1/2

x - number of sections (1 ÷ 6)

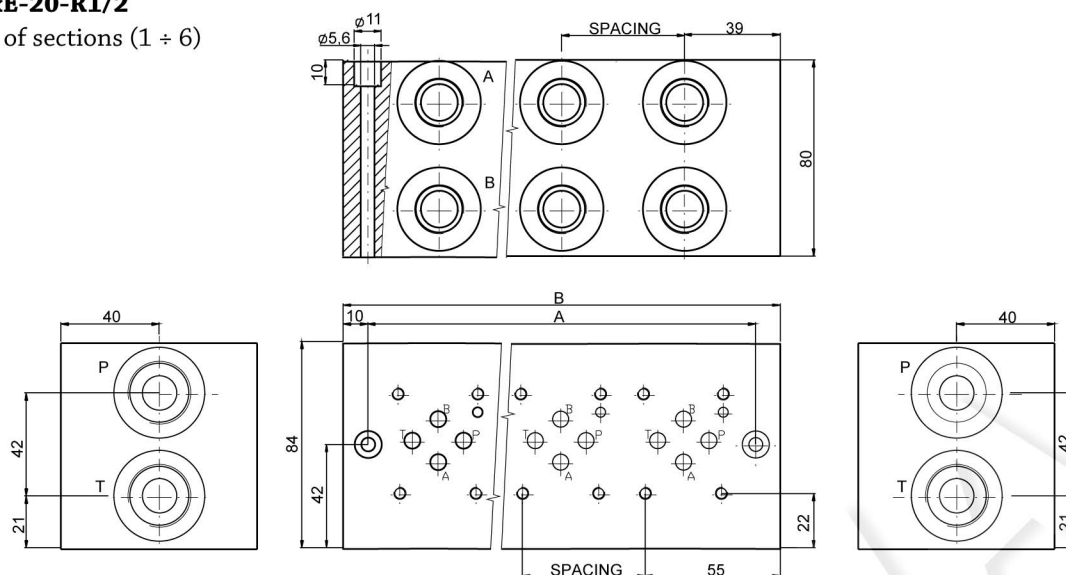

Type	x	A	B	Spacing	Weight [kg]
DGMS-3-1E-20-R 1/2	1	58	78	50	3,5
DGMS-3-2E-20-R 1/2	2	108	128	50	6
DGMS-3-3E-20-R 1/2	3	158	178	50	8,2
DGMS-3-4E-20-R 1/2	4	208	228	50	10,5
DGMS-3-5E-20-R 1/2	5	258	278	50	12,8
DGMS-3-6E-20-R 1/2	6	308	328	50	15

CAVITY DIMENSIONS

DGMS-3-xE-40-R3/8

Cavity	Thread (D)	D2	B1
P,T	G1/2"	34	15
A,B	G3/8"	28	13

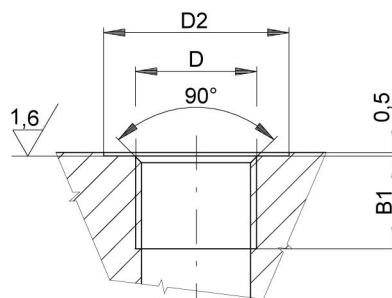

DGMS-3-xE-20-R1/2

Cavity	Thread (D)	D2	B1
P,T	G3/4"	37	16
A,B	G1/2"	31	18

Standard fitting dimensions are used for connecting ports P, T, A, B of the manifold. It is recommended to provide O-ring sealing to all pipe or hydraulic hose fittings.

INSTALLATION DIMENSIONS

According to CETOP RP 121H-R03 (CETOP 3)

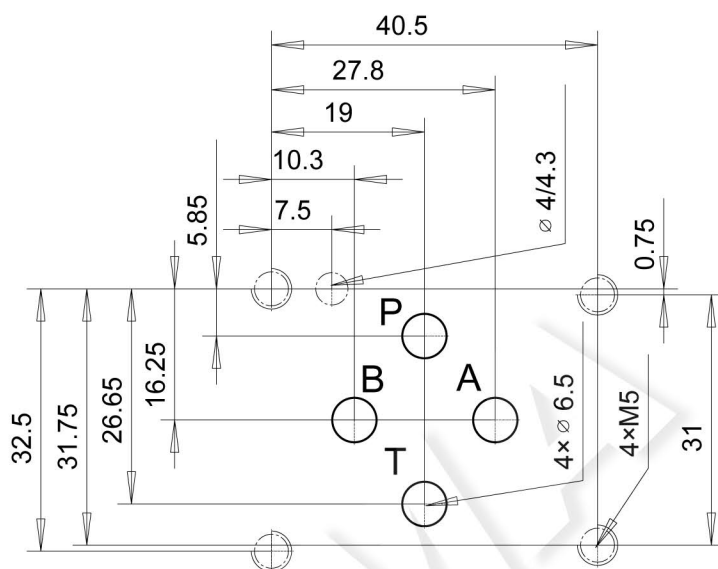

NOTES

The data is subject to change. The manufacturer reserves the right to make changes and/or improvements without prior notice. It is understood that the information in this datasheet is being used at one's own risk.